

# Novel method for on-line rheology measurement in manufacturing of non-Newtonian liquids

Fridolin Okkels<sup>1</sup>, Anders L. Østergård<sup>1</sup>, Mohammad Amin Mohammadifar<sup>2</sup>

<sup>1</sup> Fluidan ApS, Kgs. Lyngby, Denmark

<sup>2</sup> National Food Institute, Technical University of Denmark, Kgs. Lyngby, Denmark

## ABSTRACT

Companies who make or handle non-Newtonian liquids are challenged with finding a suitable process control method that can inform the process operators and control system about the current rheological properties of the liquids being processed. A range of high quality in-line viscometers are available, but commercial instruments are unable to monitor complex rheology, like viscoelasticity in real time.

We introduce a novel measurement principle that allow for automatic, continuous near-real-time rheology monitoring. The method is based on the detection of a specific differential pressure when the liquid flows through a complexly shaped channel. This pressure difference can be related to the complex rheology of the liquid.

The method, currently being prototyped, has been applied for measuring viscoelasticity in a range of different liquids, such as food stabilizers and liquid detergents, and we discuss the potential application in an industrial context.

## INTRODUCTION

Rheology of non-Newtonian liquids is normally characterized using precision laboratory instruments, typically rotational rheometers capable of applying controlled strain, strain rate and stress. Features and specifications of rotational rheometers are often impressive and given the proper sample preparation and selection of instrument

configuration, they can provide a precise and complete determination of material properties<sup>1,2</sup>.

In industrial manufacturing the application of such instruments is, however, limited by the time spent performing the analysis. Due to the delay in obtaining results, the resulting data cannot be applied directly as a means of controlling the variability of the manufacturing process. Often simpler viscometers are used in plant-laboratories, but this still demands time and manual resources, or various types of in-line viscometers are used, without the ability to characterize complex rheology.

The RheoStream® method is based on a combination of well-known capillary analysis and a novel measurement principle by which the liquid flow through a complex flow channel provides a pressure signal that depends on a rheological property, such as viscoelasticity.

## MEASUREMENT SYSTEM

### Objective of new method

The objective of the development of the RheoStream® method has been to provide a way of monitoring important rheological properties in near-real-time, when a manufacturer processes a non-Newtonian liquid. It is not an objective to provide a full characterization, but to provide enough information for the process control operator

or control system to intervene in an informed way in order to minimize production variability and reduce the off-spec rate in the process.

Therefore, the measurement system must be designed to have the characteristics of a “rheology sensor” – that is, it should be located close to the sample outlet and it should work autonomously without the need for operator handling.

### Basic principle

The measurement combines both a tubular channel, i.e. a capillary viscometer, in the following denoted the Q-cell, and a measuring cell with a complex shape, in the following denoted the c-cell.

In the Q-cell we vary the flow rates, denoted  $Q$ , within the laminar flow region, and record the corresponding pressure drop from inlet to outlet. Using the Herschel-Bulkley model the basic viscosity related parameters are determined,  $n$ ,  $K$  and  $\sigma_0$ .

It is noted that the viscoelastic properties of the liquid are not determined in this manner.

In general, in complex flow channels, the local pressure measured on the walls may depend on the rheology in a more subtle manner. For instance, for a simple channel having a slot placed perpendicular to the flow direction, the pressure at the bottom of the slot will depend not only on the viscosity and the flow rate, but also on the elastic properties, through the First Normal Stress  $N_1$  (Pa) resulting from the flow<sup>3</sup>.

The present measuring method builds on this phenomenon, but takes it a step further by introducing a complex channel shape obtained through topology optimization.

### System design

The full system thus consists of passing the liquid in laminar flow through a complex channel and a tubular channel at a predetermined set of flow rates, and then analysing the resulting differential pressure

signals to obtain the key rheological characteristics. The pressure cannot practically be measured directly in the channel walls, because of the small dimensions, and for this reason liquid filled side channels lead the pressure pulses to sensors located at the distant end of these side channels. Moreover, the instrument has a set of flushing channels and is provided with a flushing liquid (water, detergent, solvent or other) in order to keep the system of narrow channels clean to ensure long-time unattended function.

The flow and cleaning system is illustrated schematically in Fig. 1. The core of the flow system is a syringe pump with a rotary distribution valve. The syringe pump provides a controlled flow and the entire apparatus is controlled through a processor and a computer for data management and interfacing.

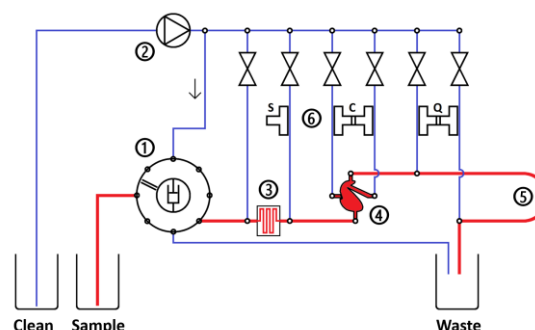

Figure 1. The flow system in RheoStream®, showing main sample flow (thick lines) and the pressure transmission and flushing flow (thin lines). (1) Syringe pump and rotary valve (2) Flushing pump (3) Heater (4) Complex measuring cell (c-cell) (5) Tubular measuring cell (Q-cell) (6) Pressure sensors (PS,  $\Delta P_c$ ,  $\Delta P_Q$ )

The temperature is carefully controlled in order to provide rheology monitoring at a predetermined temperature ( $\pm 0.5^\circ\text{C}$ ).

When in use, the instrument will suck in a new sample, typically 3-10ml, approximately once per minute, and will about one minute later provide the result of the analysis.

The sample can be fed back to the production line or it may be led to waste, if there is a requirement for protection against any contamination, e.g. in food production or fermentations.

The instrument thus requires a small sample supply, which may be taken from a mixing tank recirculation tube, and it will provide data output through an interface to the SCADA control system of the manufacturing plant, or alternatively the results may simply be displayed on a monitor in the vicinity of the apparatus. The instrument is controlled from the same SCADA system or monitor.

## FRAMEWORK FOR VISCOELASTICITY MEASUREMENT

In many cases the viscoelastic properties of a liquid is of particular interest and importance. This is for example the case for many liquid detergents, beverage concentrates, skin care products etc.

Typically, the viscoelastic parameters  $G'$  and  $G''$  are determined across a range of frequencies in an oscillatory frequency sweep on a rotational rheometer.

The Cox-Merz equation has empirically been found to relate the steady shear viscosity to oscillatory complex viscosity with equivalence in shear rates and frequencies, with good validity in many polymer dispersions<sup>3</sup>:

$$\eta(\dot{\gamma}) = \eta^*(\omega)|_{\omega=\dot{\gamma}} \quad (1)$$

The pressure drop registered in the complex c-cell,  $\Delta P_c$  (Pa), can be considered a composite of two contributions, a viscous contribution,  $\Delta P_{c,V}$ , and a viscoelastic contribution,  $\Delta P_{VE}$ , which derives from the First Normal Stress  $N_1$ <sup>(4)</sup>:

$$\Delta P_{VE} = \Delta P_c - \Delta P_{c,V} \quad (2)$$

Measurements of the pressure drop in the tubular cell,  $\Delta P_Q$  (Pa), across a range of flow

rates can be used to determine and subtract the viscous contribution, as stated in Eq. 2.

The First Normal Stress,  $N_1$ , is proportional to this  $\Delta P_{VE}$ <sup>4</sup>:

$$N_1 = k_1 \Delta P_{VE} \quad (3)$$

An extension of the application area of the Cox-Merz relation provides a second useful relationship which relates the elastic moduli  $G'$  to the  $N_1$ <sup>5</sup>:

$$G' = C N_1^\alpha \dot{\gamma}_c^{2(1-\alpha)} \quad (4)$$

Here,  $\dot{\gamma}_c$  denotes the characteristic shear rate in the c-cell and  $C$  and  $\alpha$  are calibration constants.

Combining Eq. 3 and 4 gives an explicit relation for determining the elastic modulus  $G'$  (Pa), with a new proportionality-factor  $\hat{C}$

$$G'(f_c) = \hat{C} \Delta p_{VE}^\alpha \dot{\gamma}_c^{2(1-\alpha)} \quad (5)$$

In Eq. 5  $f_c$  denotes the equivalent frequency in a standard rotational rheometer.

By another extension of the Cox-Merz relation an estimate of the complex moduli ( $G^*$ ) is obtained from a rescaling of the shear-stress  $\sigma$ .

Having estimated  $G^*$  and  $G'$ , the viscous moduli  $G''$  follows by definition.

$$G'' = \sqrt{(G^*)^2 - (G')^2} \quad (6)$$

## INSTRUMENT SET-UP AND MEASUREMENT

The analytical method presented here is not a direct measurement of distinct rheological parameters, based on “first principles”. Rather, the instrument must be set up to fit a certain type of liquid, by using the framework provided above to determine a number of proportionality constants and other empirical parameters through a

correlation to reference rheometer measurements. The empirical constants are determined for each type of liquid, and will have a good validity within a certain variation of liquids, close to the liquid used for set-up, and will cover the variation range expected within a given manufacturing process.

Once the set-up is done (the empirical parameters are determined), the instrument is used in “measurement mode”.

The empirical parameters are now kept constant, and any changes in the liquid are recorded as changes in  $\Delta P_Q$  and  $\Delta P_c$ . For each new sample, these differential pressure levels are recorded for 2-5 different flow rates. These pressure signals are in turn, using the relations illustrated above, converted to updated estimates of the key rheological parameters, such as  $n$ ,  $K$ ,  $G'$  and  $G''$ . For most liquids, the recording of signals across 2-5 flow rates, and the subsequent automated numerical analysis can be done within one minute.

More practical evidence is still required to determine the span of validity of a set of empirical constants as well as the variety of liquids that can be characterized. It is well known, that the Cox-Merz relation is not valid for all types of rheology-forming mechanisms, and more studies are needed to determine how widely, across liquid types, the RheoStream® method is robust.

#### EXAMPLE

The following example is based on a commercially available liquid laundry detergent. This liquid is weakly gel-like with clear visco-elastic properties. We measure on two samples, where the first is the undiluted liquid detergent (denoted 100%), and the second is a diluted sample consisting of 90% liquid detergent and 10% demineralized water (w/w) (denoted 90%). Both samples were measured on the RheoStream® and on a standard rotational rheometer (Haake MARS), where the measurements on the

standard rheometer were used as a reference validation.

As for standard tube capillary viscometers, we obtain the flow curves by rescaling the pressure drop along the Q-cell,  $\Delta P_Q$  (Pa) to obtain the shear stress ( $\sigma$ ) and using a power law compensated rescaling of the flow rate<sup>6</sup> to obtain the shear rate ( $\dot{\gamma}$ ).

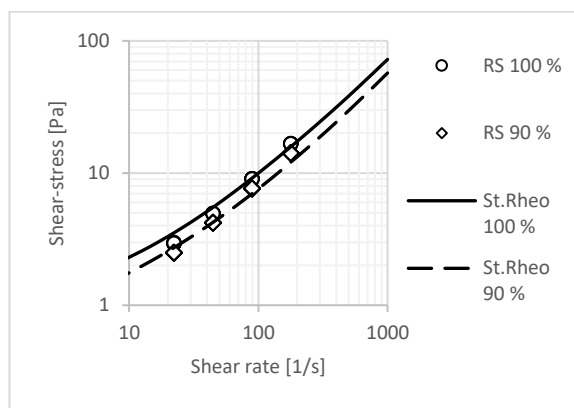

Figure 2. Flow curves of liquid detergents. Recorded using standard rheometer (lines) and using RheoStream (symbols). Concentrated (100%) and diluted (90%) detergent.

For measuring the viscoelastic properties, we apply the framework outlined above. For frequencies above 3 Hz in the oscillatory analysis by the Haake MARS the prescribed constant strain (%) could not be obtained, resulting in unsteady measurements. This limitation is illustrated in the following figures by having dotted lines for the high frequency standard rheometer measurements.

The Complex Moduli ( $G^*$ ) is plotted in Figure 3 as it is used in combination with the Elastic Moduli ( $G'$ ) to obtain the Viscous Moduli ( $G''$ ). Besides the modification to illustrate the limitations of the standard rheometer measurements, the notation is similar to that of the flow-curves in Figure 2.

The Elastic Moduli ( $G'$ ) are plotted in Figure 4 in a way similar to the Complex Moduli in Figure 3.

The Viscous Moduli ( $G''$ ) are plotted in Figure 5 in a way similar to the Complex Moduli in Figure 3.

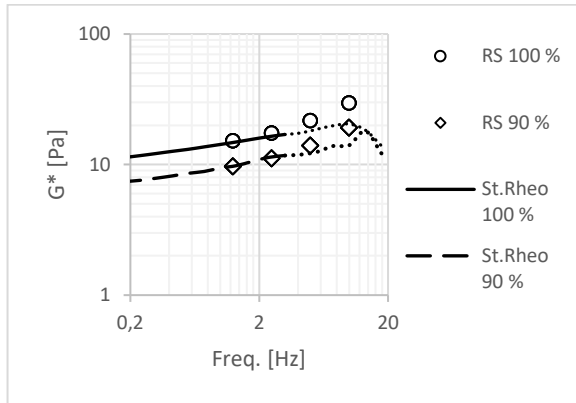

Figure 3. The complex modulus,  $G^*$ , of liquid detergents. Same notation as in Figure 2. Above 3 Hz the Std. rheometer measurement is unstable (dotted lines).

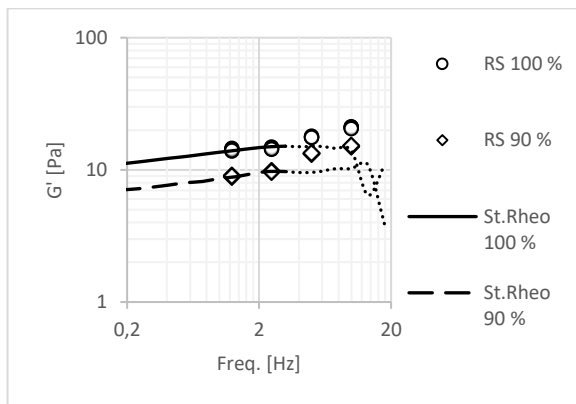

Figure 4. The elastic modulus,  $G'$ , of liquid detergents. Same notation as in Figure 3.

Because our method determines  $G''$  indirectly using Eq. 6, small uncertainties in both  $G^*$  and  $G'$  are amplified onto  $G''$  when the elastic properties are predominant in the sample liquid, as is the case with the liquid detergents used here.

The example shows that especially the elastic moduli of the two samples are clearly differentiated by the RheoStream® measurements and in good alignment with the similar standard rheometer measurements. For the Viscous Moduli, the two samples are differentiated, but the

agreement to the related standard rheometer measurements is not quite as good, due to the amplification of uncertainties as explained.

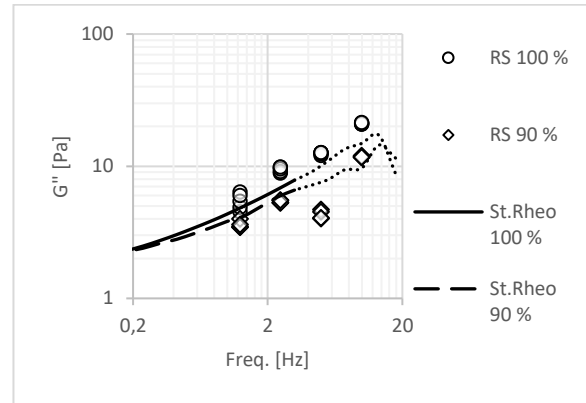

Figure 5. Viscous (loss) modulus,  $G''$ , of liquid detergents. Same notation as in Figure 3.

## PERSPECTIVES

A wide range of industrial sensors are available to provide detailed information of pH, temperature, density, flow, optical appearance, and even chemical composition, and thus allows the process operator to “look inside” the stainless-steel tubes and tanks, and to adjust the process when needed. However, manufacturing industries making or handling complex non-Newtonian liquids have long been searching for similar online analytical tools that will allow them to monitor how the critical rheology develops in their processes. The development of RheoStream®, and its adaptation to application in a range of processes may provide this tool.

The new technology presented here still needs to be proven in many more applications, and more work is needed to better understand the applicability. Currently work is ongoing with paints, skin care products, soaps & detergents, foods and beverages etc. The current instrument prototypes work at near-ambient pressure and temperatures from 10-60°C. Many more potential application areas can be addressed, particularly as instrument version operating

F. Okkels et al.

at higher pressure and temperature ranges are developed.

Having near-real-time information will reduce the resources spent on frequent manual rheometer measurements, but more significantly, it will allow process operators to significantly improve their control, which will in turn reduce the need for discarding or reprocessing off-spec batches, and will enable a faster approval and release of the product. Furthermore, when any changes in input variables (process settings or raw materials) are reflected immediately in up-to-the-minute rheological information, the process operators and their organizations will soon be climbing a steep learning curve, giving them new insights into the control of their processes. Rheology will move from being a specialty of people in white lab coats to become a tool being used across the factory floor.

## REFERENCES

1. Malkin, A. Y. and Isayev, A. I. (2017), "Rheology: Concepts, Methods, and Applications", ChemTec Publishing, Toronto.
2. Ewoldt, R.H., Johnston, M.T. and Caretta, L.M. (2015), "Experimental challenges of shear rheology: how to avoid bad data," in: Spagnolie, S. (Editor), "Complex Fluids in Biological Systems", Springer Verlag, New York, pp 207-241.
3. Cox, W.P. and Merz, E.H. (1958), "Correlation of dynamic and steady flow viscosities", *Journal of Polymer Science*, **28**, 619-622.
4. Baird, D. G. (2008), "First normal stress difference measurements for polymer melts at high shear rates in a slit-die using hole and exit pressure data", *J. Non-*

*Newtonian Fluid Mech.* **148**, 13–23.

5. Cogswell, F. N. (1972), "Converging flow of polymer melts in extrusion dies", *Polymer Engineering & Science*, **12** (1), 64-73.
6. Steffe, J. F. (1996), "Rheological Methods in Food Engineering", *Agricultural Engineering* (Vol. 23).